

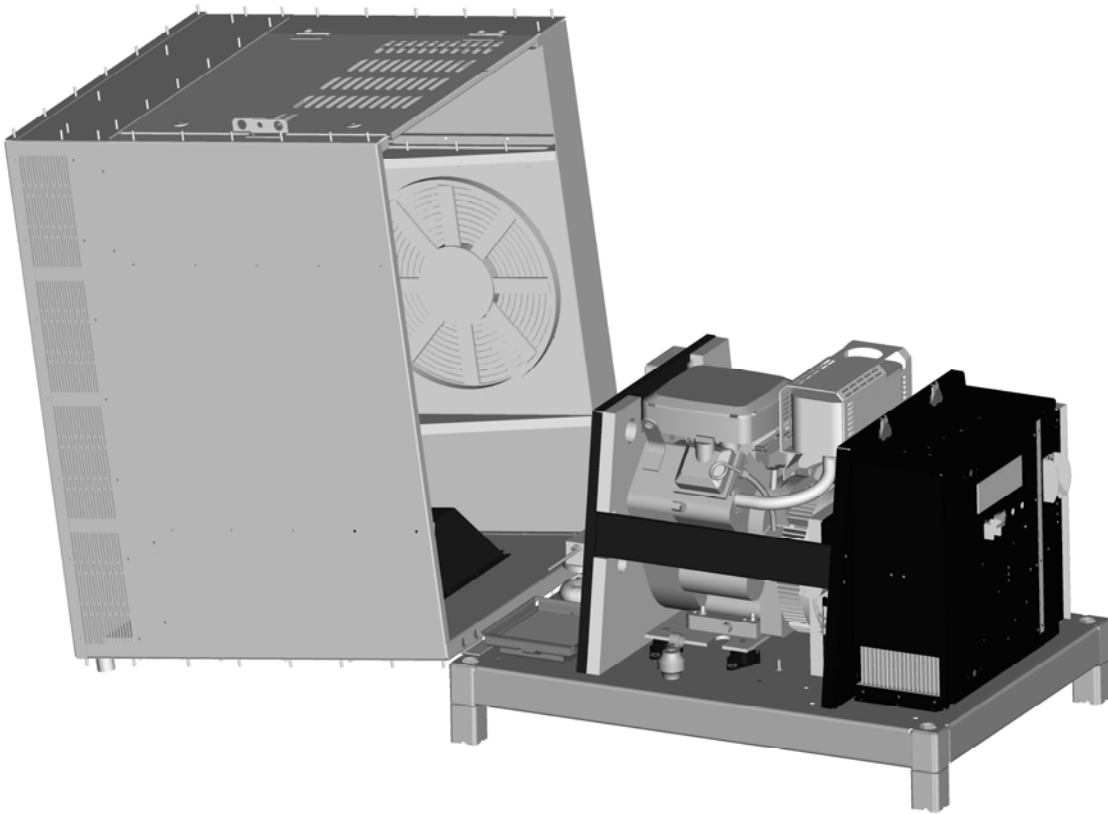

POWER PRODUCTS



**DC GENSET
5.5 kW & 4.5 kW
OPERATION MANUAL**

 **WARNING:** 

The engine exhaust from this product contains chemicals known to the State of California to cause cancer, birth defects or other reproductive harm.

Table of Contents

SAFETY PRECAUTIONS	2
INTRODUCTION	4
Important Safety Instructions	4
Model Identification	4
About the Genset	4
Fuel Recommendations	5
Engine Oil Recommendations	5
Starting Batteries	5
OPERATION	6
Genset Control Panel	6
Remote Control and Monitoring	6
Starting and Stopping the Genset	9
Exercising the Genset	9
Troubleshooting	9
PERIODIC MAINTENANCE	11
Conducting General Inspections	12
Checking Engine Oil Level	13
Changing Engine Oil and Oil Filter	13
Maintaining Battery and Battery Connections	13
Replacing Spark Plugs	14
Replacing Air Filter Element	15
SPECIFICATIONS	16
INFORMATION FOR CALIFORNIA GENSET USERS	17
MAINTENANCE RECORD	18

SAFETY PRECAUTIONS

Thoroughly read the **OPERATOR'S MANUAL** before operating the genset. Safe operation and top performance can only be obtained when equipment is operated and maintained properly.

The following symbols in this manual alert you to potential hazards to the operator, service person and equipment.

⚠ DANGER alerts you to an immediate hazard which will result in severe personal injury or death.

⚠ WARNING alerts you to a hazard or unsafe practice which can result in severe personal injury or death.

⚠ CAUTION alerts you to a hazard or unsafe practice which can result in personal injury or equipment damage.

Electricity, fuel, exhaust, moving parts and batteries present hazards which can result in severe personal injury or death.

GENERAL PRECAUTIONS

- Keep ABC fire extinguishers handy
- Make sure all fasteners have been secured to the proper torque setting
- Keep the genset and its compartment clean. Excess oil and oily rags can catch fire. Dirt and gear stowed in the compartment can restrict cooling air.
- Before working on the genset, disconnect the negative (-) battery cable at the battery to prevent accidental starting.

- Use caution when making adjustments while the genset is running-hot, moving or electrically live parts can cause severe personal injury or death.
- Used engine oil has been identified by some state and federal agencies as causing cancer or reproductive toxicity. Do not ingest, inhale, or contact used oil or its vapors.
- Do not work on the genset when mentally or physically fatigued or after consuming alcohol or drugs.

Carefully follow all applicable local, state and federal codes.

GENERATOR VOLTAGE IS DEADLY!

- Generator output connections must be made by a qualified electrician in accordance with applicable codes.
- Use caution when working on live electrical equipment. Remove jewelry, make sure clothing and shoes are dry and stand on a dry wooden platform.

ENGINE EXHAUST IS DEADLY!

- Learn symptoms of carbon monoxide poisoning in the Operator's Manual.
- The exhaust system must be installed in accordance with the genset Installation Manual. Engine cooling air must not be used for heating the working or living space or compartment.
- Make sure there is ample fresh air when operating the genset in a confined area.

FUEL IS FLAMMABLE AND EXPLOSIVE

- Do not smoke or turn electrical switches ON or OFF where fuel flames are present or in areas sharing ventilation with fuel tanks or equipment. Keep flame, sparks, pilot lights, arc-producing equipment and all other sources of ignition well away.
- Fuel lines must be secured, free of leaks and separated or shielded from electrical wiring.
- Leaks can lead to explosive accumulations of gas. Natural gas rises when released and can accumulate under hoods and inside houses and buildings. LPG sinks when released and can accumulate inside housings and basements and other below-grade spaces. Prevent leaks and the accumulation of gas.

BATTERY GAS IS EXPLOSIVE

- Wear safety glasses and do not smoke while servicing batteries.
- When disconnecting or reconnecting battery cables, always disconnect the negative (-) battery cable first and reconnect it last to reduce arcing.

MOVING PARTS CAN CAUSE SEVERE PERSONAL INJURY OR DEATH

- Do not wear loose clothing or jewelry near moving parts such as PTO shafts, fans, belts and pulleys.
- Keep hands away from moving parts.
- Keep guards in place over fans, belts, pulleys, etc.

INTRODUCTION

IMPORTANT SAFETY INSTRUCTIONS

SAVE THESE INSTRUCTIONS-This manual covers the GCAB and GCAC series of generator sets (gensets). The sections Operation, Periodic Maintenance and Specifications provide the instructions and information necessary to operate and maintain the genset. The owner is responsible for maintenance in accordance with the *Periodic Maintenance Schedule* (Page 11). Always carry this manual to the site and observe its instructions and safety precautions.

MODEL IDENTIFICATION

When contacting a Cummins distributor for parts and service be ready to provide the model and serial numbers on the genset nameplate (Figure 1). Genuine Cummins replacements parts are recommended for best performance and safety.

ABOUT THE GENSET

The genset (Figure 1) is used as standby for a 24 VDC or 48 VDC power supply, which is normally

powered by commercial AC power. It monitors the commercial AC and DC bus voltages in the connected equipment and automatically assumes start mode if AC power fails or DC bus voltage falls below the trigger voltage (25 or 49 VDC).

Start mode includes a 30 second time delay. If AC power is restored or DC bus voltage rises above the set point (26 or 52 VDC) within the 30 second waiting period, the genset will resume standby mode. If not, the genset starts, warms up for 45 seconds, matches output voltage to DC bus voltage (by adjusting engine speed) and connects to the bus.

The genset continues to power the DC bus load in parallel with the DC power supply batteries until AC power is restored or DC bus voltage is 1 volt higher than the genset set point (27 or 53 VDC). The genset then disconnects from the DC bus but continues to run, recharging its starting battery. The genset shuts down and resumes standby mode in 15 minutes if AC power and DC bus voltage remains stable.

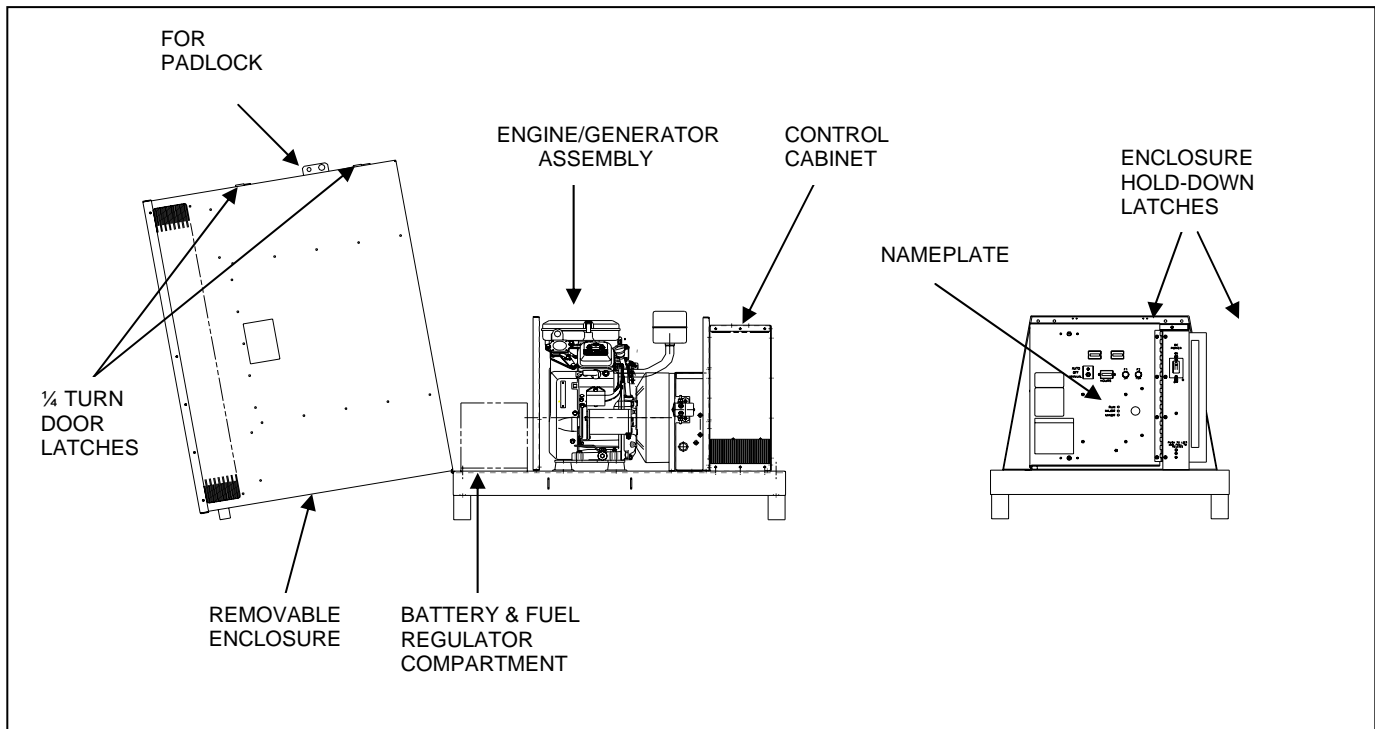

Figure 1. TYPICAL GENSET

FUEL RECOMMENDATIONS

⚠️WARNING Gaseous fuels are flammable and explosive and can cause severe personal injury or death. Do not smoke if you smell gas, are near fuel tank or fuel-burning equipment or are in an area sharing ventilation with such equipment. Keep flames, sparks, pilot lights and electrical switches and arc-producing equipment and all other sources of ignition well away. Keep a type ABC fire extinguisher handy.

NFPA Standard No. 58 requires all persons handling and operating LPG to be trained in proper handling and operating procedures.

When natural gas is the fuel being used, use commercially available natural gas fuel having a methane content of at least 90% (by volume).

When LPG (liquefied petroleum gas) is the fuel being used, use grade HD-5 or equivalent consisting of at least 90 percent propane. Commercial LPG may contain more than 2.5% butane, which can result in poor fuel vaporization and poor engine starting in ambient temperature below 32°F (0°C).

Satisfactory performance requires that the gas (natural gas or LPG) be supplied at a pressure within the range indicated in the *Specifications* section.

⚠️WARNING High gas supply pressure can cause gas leaks which can lead to fire and severe personal injury or death. Gas supply pressure must be adjusted to Specifications by qualified personnel.

ENGINE OIL RECOMMENDATIONS

Use Mobil 1 Formula 15W-50 synthetic motor oil or equivalent.

STARTING BATTERIES

The 12 volt starting battery is mounted inside the genset enclosure (Page 14). A battery charger powered by the commercial AC source is provided to keep the battery charged when the genset is in standby. An engine battery charger recharges the battery when the genset is running. See Maintaining Battery and Battery Connections (Page 13).

OPERATION

GENSET CONTROL PANEL

The genset control cabinet (Figure 2) is located inside the genset enclosure (Figure 1). The control panel has the following features:

Control Switch (AUTO-OFF-MANUAL) – The three switch positions have the following functions:

- **AUTO** is the normal position. The genset will automatically monitor commercial AC power and DC bus voltage and start and run whenever AC power fails or DC bus voltage falls below the factory preset level. Remote start **is** enabled.

CAUTION Failure to push the control switch to **AUTO** before leaving the site will render the genset unavailable for automatic standby service.

- **OFF** disables the genset. Remote start **is not** enabled.
- **MANUAL** starts and runs the genset and allows the genset to supply power to the DC bus if voltage falls below the factory preset level. The genset can be run disconnected from the DC bus during service (for load bank tests) because Open Circuit Breaker Shutdown is disabled. All other alarms and shutdowns are active. Remote start **is not** enabled.

DC Output Meters (Optional) – These meters indicate DC output volts and amperes.

Hour Meter – The hour meter records genset operating time in hours. It cannot be reset.

Panel Fuses – These fuses protect the AC and DC control circuits from shorts to ground. Replace with fuses of the same type and ratings.

DC Output Circuit Breaker – This circuit breaker protects the genset from over current and disconnects it from the DC bus.

Intrusion Switch – This switch closes contacts for a remote alarm which warns that the

genset access door is open. Disable the switch by pushing the knob left and pulling out. The switch resets when the door is closed.

Lamp (Green) – This lamp indicates that the genset is running and supplying power.

Major Fault Alarm Lamp (Red) – This lamp indicates that genset shutdown was due to one of the following faults:

- Engine Stopped (See *Troubleshooting*)
- Overcrank
- Circuit Breaker Open (off or tripped)
- Engine or Heat Sink Overtemperature
- Overspeed
- Overvoltage (DC Bus)
- Low DC Bus Voltage
- Gas Leak (only with Annunciator Panel)
- Pad Shear (only with Annunciator Panel)

Service the genset as necessary and reset the controller by pushing the control switch to OFF. See *Troubleshooting*.

Minor Fault Alarm Lamp (Yellow) – This lamp warns of one of the following abnormal conditions that could lead to shutdown:

- Remote of Manual Start or Exercise Mode
- Genset started up at low DC bus voltage

Annunciator Panel (Optional) – Table 1 summarizes what each annunciator lamp indicates. Push the lamp test switch to test the annunciator lamps, which should all light. Service the genset as necessary. See *Troubleshooting*.

REMOTE CONTROL AND MONITORING

The genset can be connected for Remote Start and for remote monitoring of Run, Major/Minor faults and Intrusion.

The Annunciator Panel, when provided, has connectors inside the box for remote as well as local annunciation of all of the alarms in Table 1.

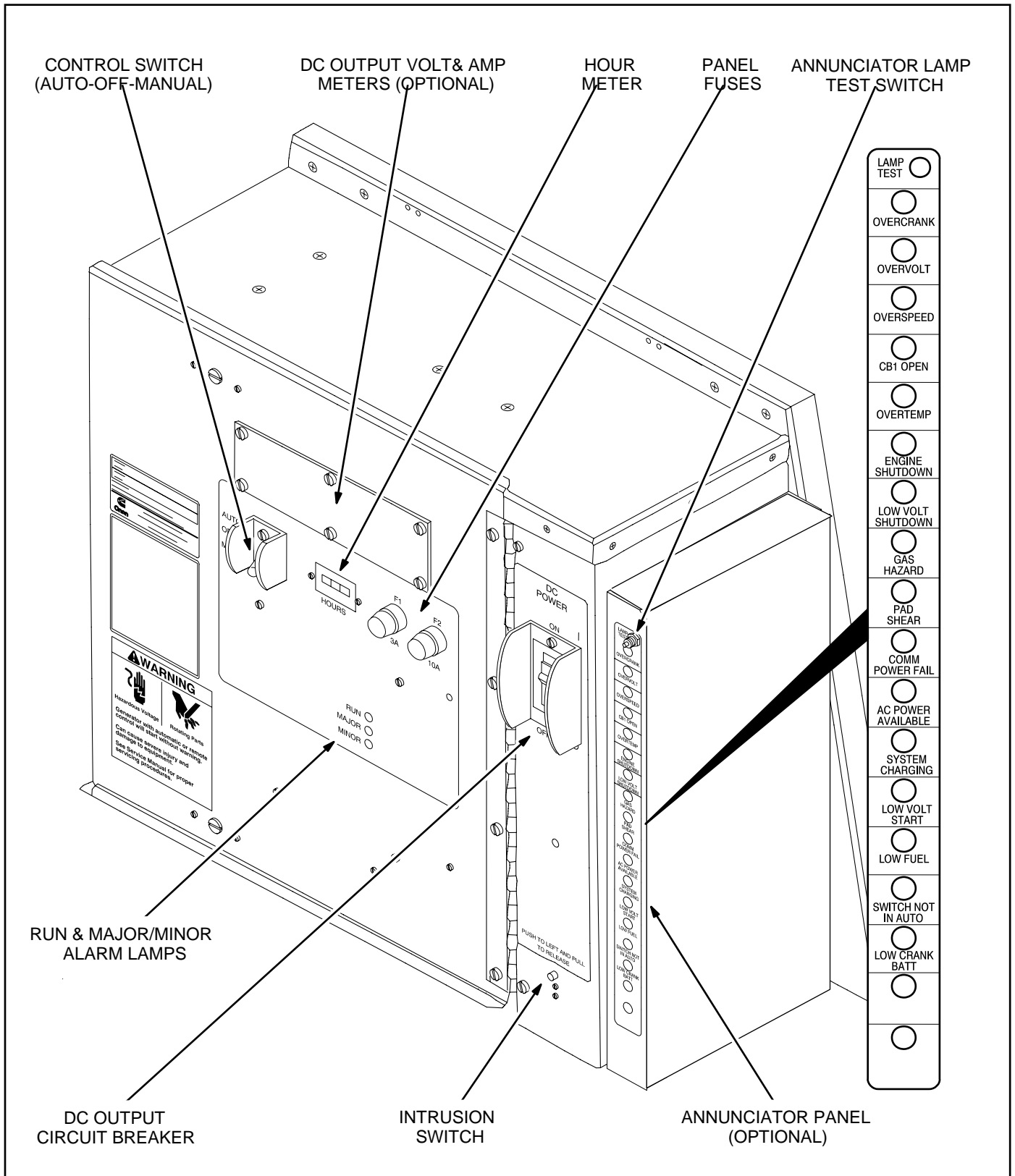

FIGURE 2. CONTROL CABINET

TABLE 1. ANNUNCIATOR PANEL LAMPS (OPTIONAL)

Lamp	Description	Alarm Type
LAMP TEST	Pressing the lamp test switch should light all lamps and clear all faults	-
OVERCRANK	Red-Shutdown because engine failed to start (five 20 second cranks with 15 second rests)	Major
OVERVOLT	Red-Shutdown because DC bus exceeded maximum allowable voltage: 29.5 VDC or 59 VDC (or other).	Major
OVERSPEED	Red-Shutdown because engine exceeded 4100 RPM	Major
CB1 OPEN	Red-Shutdown because the DC output circuit breaker is Open (off or tripped). (This shutdown is disabled when the control switch is in MANUAL. When the control switch is in AUTO, the genset will start, warm up and then shut down.)	Major
OVERTEMP	Red-Shutdown because of high engine or heat sink temperature.	Major
ENGINE SHUTDOWN	Red-Shutdown due to something other than annunciated by the other lamps. It could be low oil pressure.	Major
LOW VOLT SHUTDOWN	Red- Shutdown because minimum DC bus voltage cannot be attained (18 VDC or 36 VDC).	Major
GAS HAZARD	Red-Shutdown because of a possible gas leak.	Major
PAD SHEAR	Red-Shutdown because the genset has shifted from its installed position	Major
COMM POWER FAIL	Red-Indicates that commercial AC power is not available.	-
AC POWER AVAILABLE	Green-Indicates that commercial AC power is available.	Normal
SYSTEM CHARGING	Green-Indicates that the genset is running and supplying power.	-
LOW VOLT START	Yellow-Indicates that the genset started for a bus voltage below the trigger voltage: 25 VDC or 50 VDC (or other).	Minor
LOW FUEL	Yellow-Indicates marginal fuel pressure at the genset.	Minor
SWITCH NOT IN AUTO	Yellow-Indicates that the control switch is not in AUTO.	Minor
LOW CRANK BATT	Yellow-Indicates that battery charger voltage is marginal (during normal operation).	Minor
SPARE	-	-
SPARE	-	-

STARTING AND STOPPING THE GENSET

Pre-Start Checks

If this is the initial startup, refer to the Installation Manual to check polarity of the connections before turning the DC output circuit breaker on. Reconnect as necessary.

Perform the maintenance instructed under *Conducting General Inspections* and any Periodic Maintenance due (Page 12).

WARNING EXHAUST GAS IS DEADLY!

All engine exhaust contains carbon monoxide, an odorless, colorless, poisonous gas that can cause unconsciousness and death. Symptoms of carbon monoxide poisoning include:

- Dizziness
- Headache
- Nausea
- Weakness and Sleepiness
- Vomiting
- Inability to Think Coherently

IF YOU EXPERIENCE ANY OF THESE SYMPTOMS, GET OUT INTO FRESH AIR IMMEDIATELY. If symptoms persist, seek medical attention.

The genset must be installed in accordance with the Installation Manual in an open area where exhaust gases can disperse. Make sure there is ample fresh air when servicing the genset in an enclosed area.

Manual Starting

Push the control switch to MANUAL. The engine should crank, start and run up to governed speed in a few seconds. The starter will disconnect automatically. If DC bus voltage is below factory preset level, the genset will connect to the DC bus after a 45 second warm-up and the green run lamp will light.

In this mode the DC output circuit breaker can be turned off without fault shutdown. Various service procedures can be performed while disconnected from the DC bus.

See *Troubleshooting* if the engine fails to start and the genset shuts down (Major Alarm and OVERCRANK lamps on).

Check for fuel and exhaust leaks. Stop the genset immediately if there is a fuel or exhaust leak. Fix fuel leaks immediately. Repair exhaust leaks before continuing operation.

Manual Stopping

Push the control switch to OFF.

Automatic Starting and Stopping

Push the control switch to Auto for automatic starting and stopping.

 **CAUTION** The genset will not be available for automatic standby service unless you push the control switch to AUTO before leaving the site.

EXERCISING THE GENSET

A programmable 7-day, 1-to-8-week cycle timer is available for periodically starting and running the genset. See the Installation Manual (99000187) for instructions on how to set day, cycle and duration of exercise. A 4 week cycle of 30 minute exercise is recommended.

Exercising is recommended for driving off moisture, re-lubricating the engine and removing oxides from electrical contacts. The result is better starting, higher reliability and longer engine life.

TROUBLESHOOTING

Table 2 provides basic troubleshooting guidance. Contact an authorized Cummins distributor if you have questions.

After servicing a Major Fault Alarm shutdown, reset the genset controller by pushing the control switch to OFF.

 **WARNING** Hot engine parts can cause severe burns. Always allow the engine time to cool before performing any maintenance or service.

TABLE 2. TROUBLESHOOTING

<p>⚠️WARNING Many troubleshooting procedures present hazards that can result in severe personal injury or death. Only personnel trained and experienced in servicing fuels, electricity, and machinery should perform service. Review the safety precautions on the inside cover page.</p>	
Problem	Corrective Action
<p>Engine fails to crank (Manual Start)</p>	<ul style="list-style-type: none"> a. Service or replace the starting battery and battery connections (Page 13). b. Service the battery charging circuits (engine charger and AC float charger), engine starter circuits, engine starter, or engine, as necessary, in accordance with the Service Manual.
<p>Engine cranks but fails to start. (OVERCRANK and/or MAJOR FAULT ALARM)</p>	<ul style="list-style-type: none"> a. Open any closed manual fuel shutoff valve. b. If LPG fueled, check LPG level and fill the tank as necessary (optional LOW FUEL lamp will be on). On cold days the LPG tank may have to be kept at least half full to provide the rate of vaporization necessary to keep up with genset fuel demand. c. If Natural Gas fueled and the LOW FUEL lamp (optional) is on, check with the gas supplier about restoring gas supply. d. Check engine oil level (Page 13). e. Secure spark plug cable(s) on spark plug(s) (Page 14). f. Replace spark plug(s) (Page 14). g. In colder climates consider installing the optional battery heater kit if cranking speed is too slow to start engine h. Service the engine in accordance with the Service Manual.
<p>Engine stops (MAJOR FAULT ALARM)</p>	<ul style="list-style-type: none"> a. If LPG fueled, check LPG level and fill the tank as necessary (optional LOW FUEL lamp will be on). On cold days the LPG tank may have to be kept at least half full to provide the rate of vaporization necessary to keep up with the genset fuel demand. b. If Natural Gas fueled and the LOW FUEL lamp (optional) is on, check with the gas supplier about restoring gas supply. c. Check engine oil level (Page 13). d. Secure spark plug cable(s) on spark plug(s) (Page 14). e. Replace spark plug(s) (Page 14). f. If GAS HAZARD or PAD SHEAR lamp is on, call service immediately and notify local emergency district. g. If OVERVOLT, LOWVOLT, or LOW VOLT START lamp is on, service the genset and DC power supply equipment as necessary h. If OVERTEMP lamp is on, clean the genset and remove debris restricting cooling air inlets and outlets. i. If OVERSPEED lamp is on, service the engine in accordance with the Service Manual.
<p>LOW CRANK BATT and/or MINOR FAULT ALARM</p>	<ul style="list-style-type: none"> a. Service or replace the starting battery and battery connections (Page 13). b. Service the engine battery charger in accordance with the Service Manual.
<p>No DC Output (RUN lamp not on) (CB1 OPEN and/or MAJOR FAULT ALARM)</p>	<ul style="list-style-type: none"> a. Determine why the DC output circuit breaker tripped and service the genset and DC power supply equipment as necessary. b. Push circuit breaker to ON and control switch to AUTO if the genset is ready to provide service. c. Service the genset and DC power supply equipment as necessary.

PERIODIC MAINTENANCE

Periodic maintenance is essential for top performance and long genset life. Use Table 3 as a guide for normal periodic maintenance. Maintenance should be more frequent in hot or dusty environments, as the footnotes indicate.

Maintenance, replacement or repair of emission control devices and systems may be performed by an engine repair establishment or individual. However, warranty work must be completed by an authorized Cummins distributor.

Record all maintenance and service performed in the Maintenance Record (Page 18).

TABLE 3. PERIODIC MAINTENANCE SCHEDULE

MAINTENANCE PROCEDURE	MAINTENANCE FREQUENCY					
	After First 25 Hours	Every 6 Months	Every Year or 50 Hours	Every Year or 100 Hours	Every 2 Years	Page
Adjust Valve Lash	X ⁴			X ⁴		-
General Inspection		X				12
Check Engine Oil Level		X				13
Check Battery		X				13
Change Engine Oil	X		X ^{1,2}	X		13
Replace Engine Oil Filter	X			X ^{1,2}		13
Replace Spark Plugs				X ³		13
Replace Air Filter				X ^{1,3}		15
Replace Flexible Fuel Line				X		15
Replace Starting Battery					X	-

- 1- Perform more often when operating in dusty environments
- 2- Perform more often when operating in hot weather
- 3- Perform sooner if engine performance deteriorates
- 4- Must be performed by a qualified mechanic (authorized Cummins distributor)

CONDUCTING GENERAL INSPECTIONS

Unlock the padlock on the genset enclosure door, unlatch the two quarter-turn door latches and swing the door out and detach it (Figure 1, Page 4). Reach in above the control box and release the two enclosure hold-down latches. Swing the enclosure up and out and rest it on its bumpers or detach it from the genset.

⚠️WARNING Automatic startup while performing maintenance or service can cause severe personal injury or death. Push the control switch to OFF and disconnect the negative (-) battery cable from the battery to keep the genset from starting while working on it.

Oil Level

See *Checking Engine Oil Level* (Page 13).

Battery and Battery Connections

See *Maintaining Battery and Battery Connections* (Page 13).

Fuel System

If you smell gas close the manual gas shutoff valve immediately and call for service. Check fuel supply lines, flexible hose and fittings for leaks, cuts, cracks, and abrasions. Make sure the fuel

line is not rubbing against other parts. Replace worn or damaged parts before leaks occur.

⚠️WARNING Gaseous fuels are highly flammable and explosive and can cause severe personal injury or death. Repair leaks immediately.

Exhaust System

Start the genset manually (Page 9) and look and listen for exhaust leaks. Repair as necessary before continuing operation.

Mechanical

Look for mechanical damage, listen for unusual noises and vibrations and service as necessary. Clear genset air inlet and outlet openings of debris and remove accumulated dust and dirt from the genset. Do not clean the genset while it is running or still hot. Keep the generator, air cleaner and electrical components from getting wet.

⚠️WARNING Wear safety glasses when using compressed air, a pressure washer or a steam cleaner to avoid severe eye injury.

CHECKING ENGINE OIL LEVEL

⚠️WARNING State and federal agencies have determined that contact with used engine oil can cause cancer or reproductive toxicity. Avoid skin contact and breathing of vapors. Use rubber gloves and wash exposed skin.

⚠️WARNING Crankcase pressure can blow hot engine oil out the fill opening causing severe burns. Always stop the genset before removing the oil fill cap.

1. Stop the genset before checking oil level.
2. Unscrew the oil fill cap and wipe oil off the dipstick (Figure 3). Screw the cap back on, remove it, and check the oil level on the dip stick.
3. Add or drain oil as necessary. Use Mobil 1 Formula 15W-50 synthetic motor oil or equivalent.

⚠️CAUTION Too much oil can cause high oil consumption. Too little oil can cause severe engine damage. Keep the oil level between the FULL and ADD marks.

4. Screw on the oil fill cap securely.

CHANGING ENGINE OIL AND OIL FILTER

Refer to Table 3 for scheduled engine oil change. Change oil more often in dusty environments.

1. Run the genset until warm and stop it. Place a pan underneath the oil drain hose and filter (Figure 3) and open the drain valve. Reclose the drain valve when oil stops draining.
2. Spin off the old oil filter, making sure the gasket comes off, and wipe the mating engine boss clean.
3. Apply a film of oil to the new filter gasket and spin the filter on by hand until the gasket just touches the mating engine

boss. Then turn the filter not more than ½ to ¾ turns.

4. Refill with Mobil 1 Formula 15W-50 synthetic motor oil or equivalent. See Specifications for oil capacity. Check oil level and add or drain as necessary (See *Checking Engine Oil Level*).
5. Dispose of the used oil and filter in accordance with local environmental regulations.

MAINTAINING BATTERY AND BATTERY CONNECTIONS

Refer to Table 3 for scheduled battery maintenance and replacement. The starting battery is mounted inside the genset enclosure (Figure 3). Refer to the battery manufacturer's instructions regarding battery maintenance and Specifications (Page 16) regarding minimum battery ratings.

Keep battery terminals clean and tight. Always make sure which terminal is positive (+) and which is negative (-) before making battery connections, always removing the negative (-) cable first and reconnecting it last to reduce arcing.

Service the battery charging systems if the battery does not keep its charge (engine charger and AC float charger).

⚠️WARNING Flames, sparks or arcing at the battery terminals, light switches or other equipment can ignite battery gas causing severe personal injury. Do not smoke-Ventilate the area before working on or near a battery-Wear safety glasses-Switch work lamps ON and OFF away from the battery-Do not disconnect battery cables while genset is running or a battery charger is on-Always disconnect the negative (-) cable first and reconnect it last.

REPLACE SPARK PLUGS

Refer to Table 3 for scheduled spark plug(s) replacement. The spark plug(s) (Figure 3) must be in good condition for proper engine starting and performance. A spark plug that fouls frequently or has heavy soot deposits indicates

the need for engine service. See *Troubleshooting*.

To prevent cross threading a spark plug, always thread it in by hand until it seats. Then torque to 15 lb-ft (19 N-m).

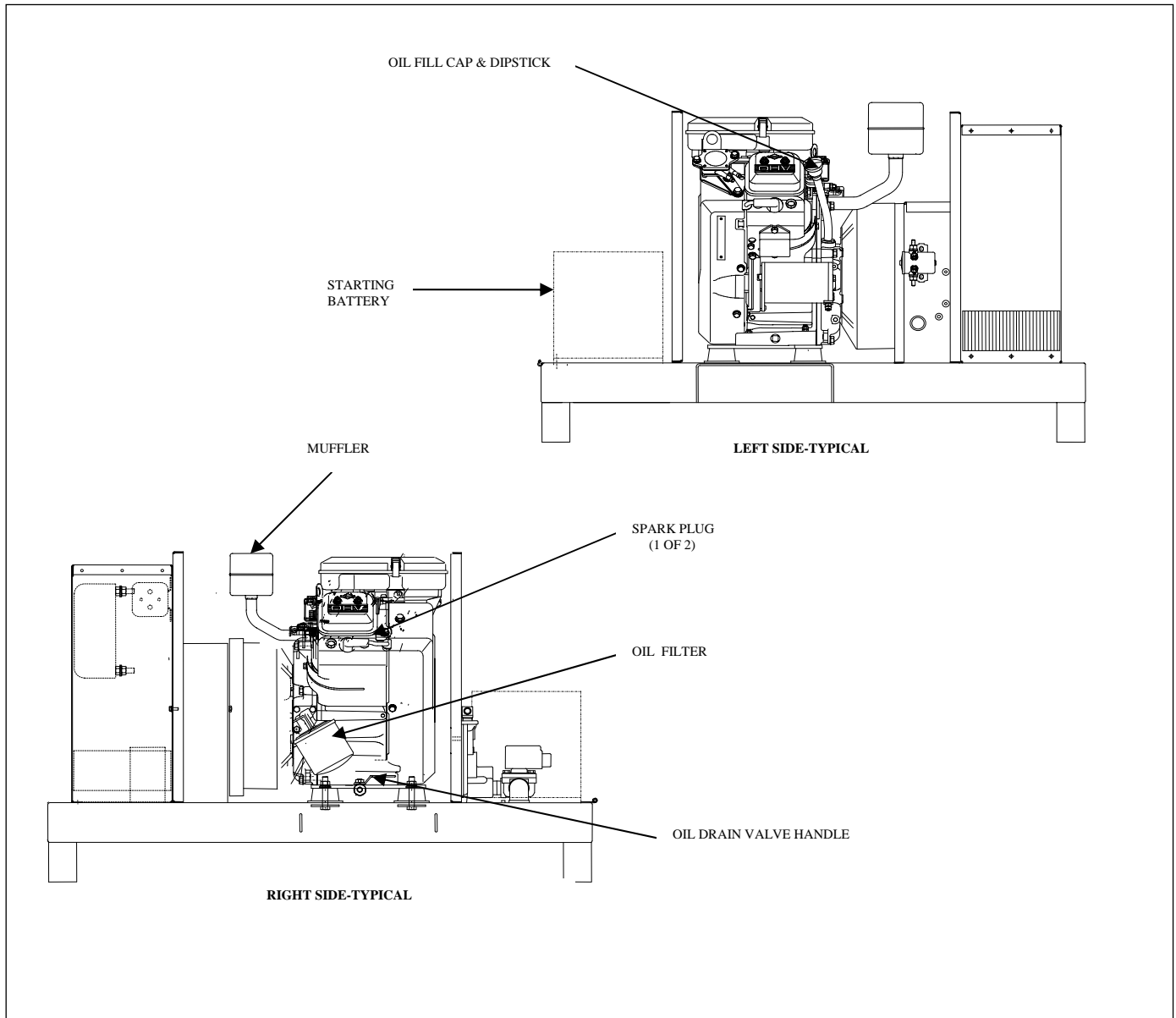

FIGURE 3. MAINTENANCE ITEMS

REPLACING AIR FILTER ELEMENT

Refer to Table 3 for scheduled air filter replacement. Replace the filter and pre-cleaner elements (Figure 4) more often in dusty environments.

Carefully remove the cover(s) and filter elements to avoid debris from entering the engine. Discard the old filter and pre-cleaner elements. Saturate the new pre-cleaner element in engine oil and squeeze it dry in a clean cloth. Reassemble filter, pre-cleaner and cover(s).

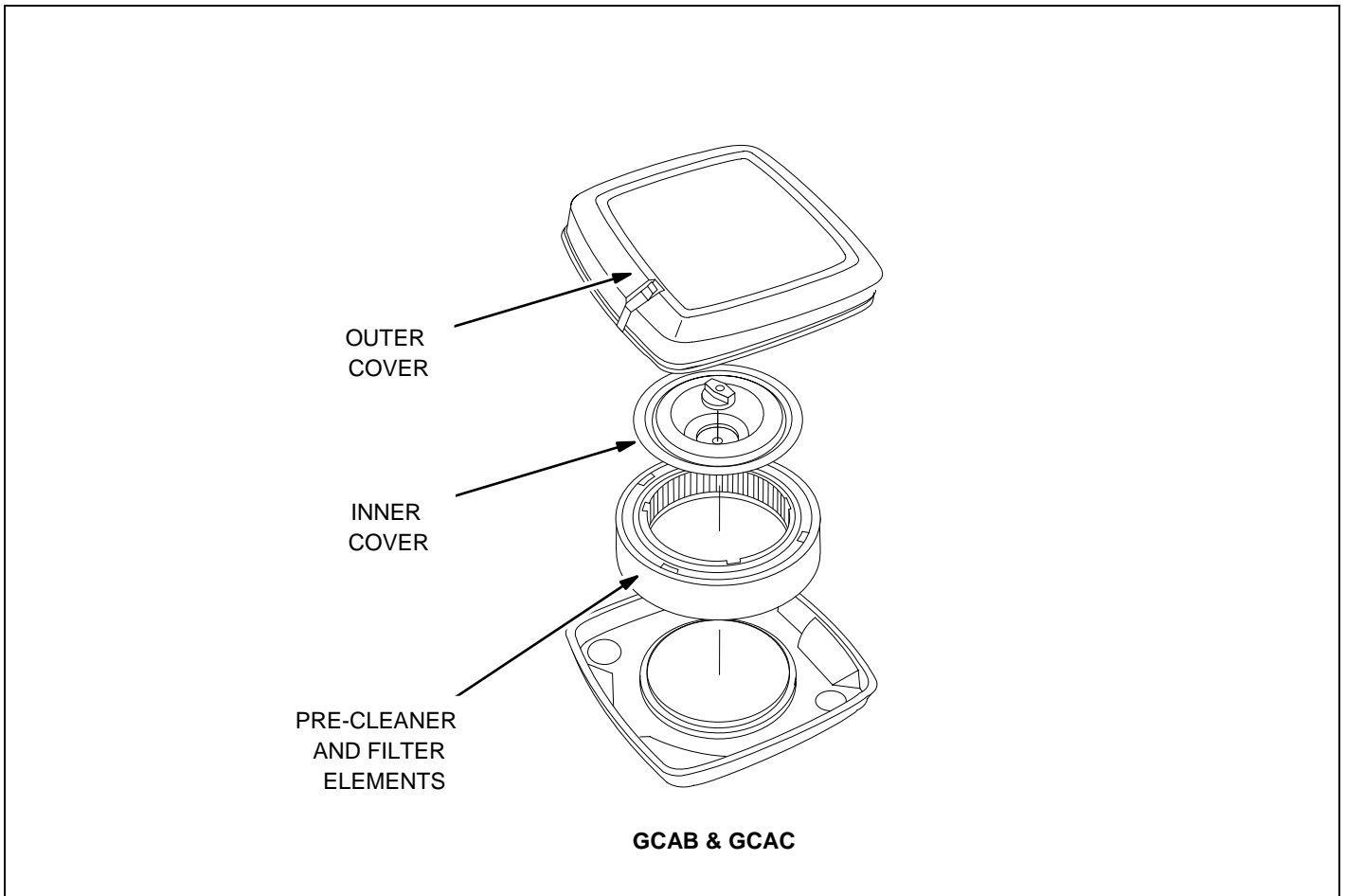

FIGURE 4. AIR FILTER AND PRE-CLEANER ELEMENTS

REPLACING FLEXIBLE FUEL LINE

Refer to Table 3 for scheduled fuel line replacement. Be sure to inspect this fuel line more often if the unit is located in a salty or other corrosive environment.

1. Locate the fuel line beneath the base of the unit near the location of the fuel regulator and starter battery.
2. Shut off fuel to the generator and bleed remaining gas contained between the shutoff and the Genset fuel regulator.
3. Disconnect the flexible fuel line from the site fuel line and unscrew from the Genset fuel assembly.
4. Replace fuel line with a new part and reconnect, ensuring all joints are properly sealed and do not leak.
5. Restore fuel to the site.

SPECIFICATIONS

	GCAB	GCAC
GENERATOR: Bearingless, 3-Phase, Permanent Magnet Alternator with Full-Wave Rectified DC Output Regulated by Engine Speed		
Power	4.5 kW	5.5 kW
Voltage	24 VDC or 48 VDC	24 VDC or 48 VDC
DC Output Circuit Breaker Rating	200 amp for 24 VDC 100 amp for 48 VDC	250 amp for 24 VDC 125 amp for 48 VDC
FUEL CONSUMPTION:		
LPG (Full load)	5.6 lbs/h	6.6 lbs/h
Natural Gas (Full load)	121 ft ³ /h	143 ft ³ /h
ENGINE: Air-Cooled, 4-Cycle, Spark-Ignited, OHV		
Model	Briggs & Stratton Vanguard 480cc	Briggs & Stratton Vanguard 570cc
Type	V-Twin	V-Twin
Displacement	29.3 in ³	34.7 in ³
Speed	Controller Regulated: 2200-4100 rpm	Controller Regulated: 2200-4100 rpm
Oil Capacity	1 ½ Quarts 1 ¾ Quarts with filter	1 ½ Quarts 1 ¾ Quarts with filter
Oil Filter	Briggs & Stratton 492932 or 5049	Briggs & Stratton 491056 or 492932
Air Filter Element	Briggs & Stratton 349018	Briggs & Stratton 349018
Air Filter Pre-Cleaner	Briggs & Stratton 272490	Briggs & Stratton 272490
Spark Plug	Briggs & Stratton 491055	Briggs & Stratton 491055
Spark Gap	0.030 inches	0.030 inches
DC CONTROL AND CRANKING SYSTEM:		
Battery Voltage	12 volt	12 volt
Battery Specs	BCI Group MF26/70 675 CCA @ 0°F	BCI Group MF26/70 675 CCA @ 0°F
INSTALLATION:		
Drawing #	60000205	60000206
Fuel Connections	¾ inch NPT	¾ inch NPT
Fuel Supply	7-13 inch WC (Water Column)	7-13 inch WC (Water Column)
Size (L x W x H)	39.1 x 28 x 31 inches	39.1 x 31 x 36.1 inches
Weight	350 lb	450 lb

INFORMATION FOR CALIFORNIA GENSET USERS

Genset engines that meet the requirements of California's Exhaust Emissions Standards state so on the engine nameplate. Refer to the engine Emission Control System Warranty Statement packaged with the manuals and Owner Warranty for terms and conditions.

MAINTENANCE RECORD



POWER

PRODUCTS

Thank you for choosing us!